



REPLACEMENT Q-JET CARBURETOR KIT INSTRUCTIONS

KITS #1920, 1921 & 1990

Performer Models 1901, 1902, 1903, 1904, 1905, 1906, 1910

Please read these instructions carefully before attempting to rebuild your carburetor. Make sure to refer to your carburetor Installation Instructions for further information if need be. If you have any questions or problems, do not hesitate to contact our **Technical Hotline** at: **(800) 416-8628** from 7:00 am to 5:00 pm, Monday through Friday, Pacific Standard Time or e-mail us at: edelbrock@edelbrock.com.

To check kit contents see exploded view of carburetor and parts description on last page. Verify that all parts underlined on list are in your kit.

Carb Kit contains all necessary parts and instructions to rebuild your Edelbrock Carburetor properly. When similar parts are contained in the Carb Kit, choose the ones that most closely match the existing parts. Some parts in the kit may not be needed.

- DISASSEMBLE** carburetor use accompanying exploded view as a guide..
 - Remove pump lever by driving roll pin through far enough to permit release of lever.
 - Remove air horn screws.
 - Remove power piston by pressing down and releasing with a snap.
 - Remove power piston spring(s).
 - Do Not turn nor remove factory-adjusted stop screw next to power piston. (APT) Adjustable part throttle.
 - Do Not turn nor remove factory-adjusted screw in aneroid cover.
 - Turn idle mixture needles clockwise and record number of turns needed to lightly bottom them, for use during reassembly. Remove needles.
 - Disassemble choke cap from housing per Figure 13 (not applicable to remote choke models).

- CLEAN** carburetor.
 - Soak the carb parts (except as noted below) in a cold immersion type carb cleaner.
 - Use mineral spirits or kerosene to clean solenoids, choke cover, aneroid, float, float bowl inserts, vacuum breaks, seals or other parts containing rubber. Do not immerse these parts in carb cleaner.
 - Blowout all passages with compressed air .
 - After a thorough cleaning of all castings and parts, pay particular attention to the cleanliness of the power piston and the body casting bore where it is housed. Any sticking of the power valve will prevent proper fuel control and affect driveability.

- REASSEMBLE** carburetor and **ADJUST** following sequence illustrated.
 - Refer to model number for specifications. Use figure 1 to find position of model number
 - Install new intermediate choke shaft seal in float bowl. Lip faces outward. On Hot Air Choke models, install additional shaft seal in

choke housing. Lip faces float bowl. Disregard for remote choke models.

- Do not install float needle pull clip into holes in float arm.
- Install power piston. Press plastic retainer into bore until flush with top of float bowl casting.
- Carefully remove pump cup (with garter spring, if used) from pump head. Install new cup (with new garter spring, if used) on pump head.

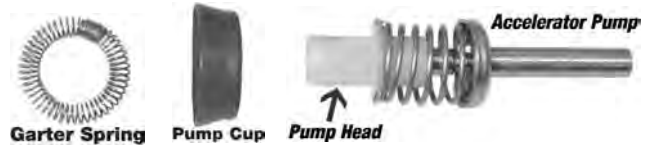

- If used, install new pump stem seal and retainer in air horn. Lip faces toward outside of carburetor. Lightly stake casting around retainer.
- Select correct air horn gasket by matching replacement to old gasket.
- Tighten air horn screws in numerical sequence per illustration. Torque screws 32-60 in-lbs.
- Install the choke cover and coil assembly per Figure 15. Use the cover gasket on hot air model only (1903). Do not use the cover gasket on electric choke model 1904, 05, 06, 10.

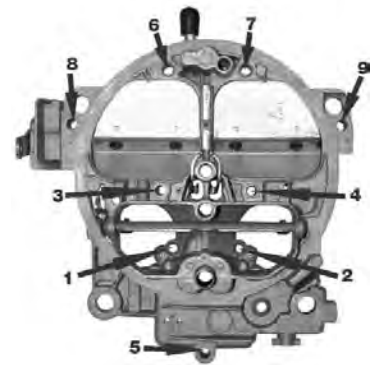

- REINSTALL** carburetor to intake manifold, torque mounting bolts to 110 in-lbs.
- ADJUST** idle mixture and speed according to vehicle manufacturer's specifications.

ADJUSTMENT SPECIFICATIONS

CARB #	FIG. 1 FLOAT SETTINGS	FIG. 2 PUMP SETTINGS		FIG. 4 AIR VALVE SPRING	FIG. 5 CHOKE COIL LEVER	FIG. 6 FAST IDLER	FIG. 7 VACUUM BREAK	FIG. 9 UN- LOADER	FIG. 13 CHOKE SETTINGS
		LEVER HOLE	DIM.						
1901 (8904S)	15/32"	INNER	13/32"	7/8 TURN	1/8"	48°	22°	40°	PER NOTCH
1902 (8905S)	15/32"	INNER	13/32"	7/8 TURN	1/8"	48°	22°	40°	PER NOTCH
1903 (8906S)	25/64"	INNER	13/32"	7/8 TURN	1/8"	48°	27°	40°	PER NOTCH
1904 1905 1906 (8907S)	25/64"	INNER	13/32"	7/8 TURN	1/8"	48°	27°	40°	PER NOTCH
1910 (8908S)	19/64"	INNER	5/8"	1 TURN	1/8"	48°	27°	40°	PER NOTCH

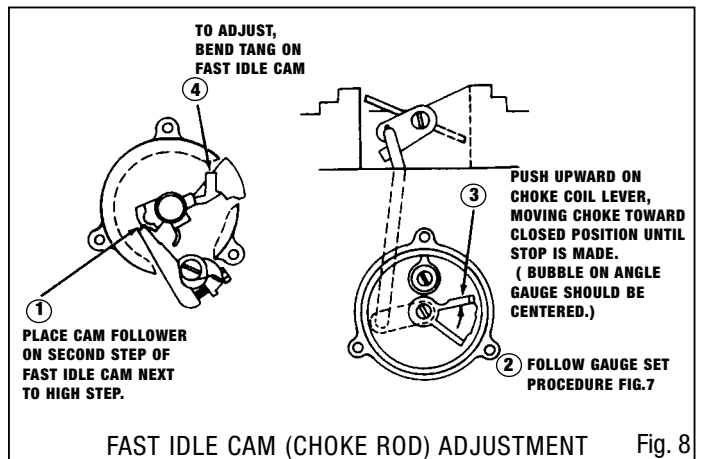
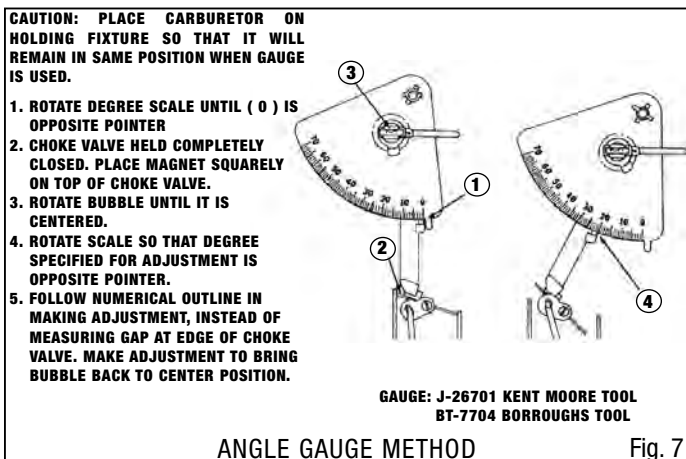
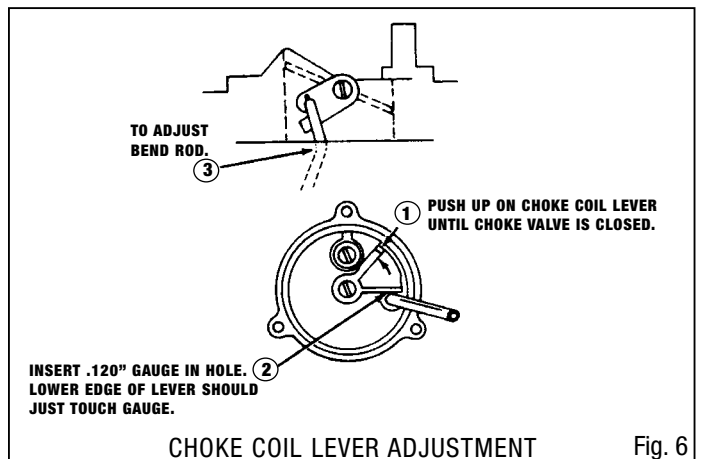
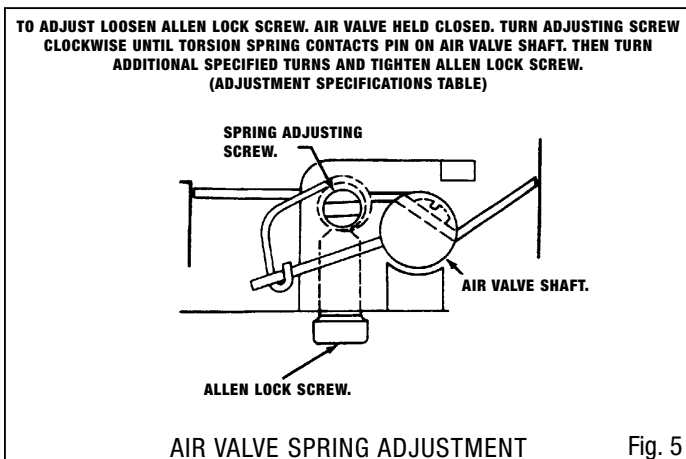
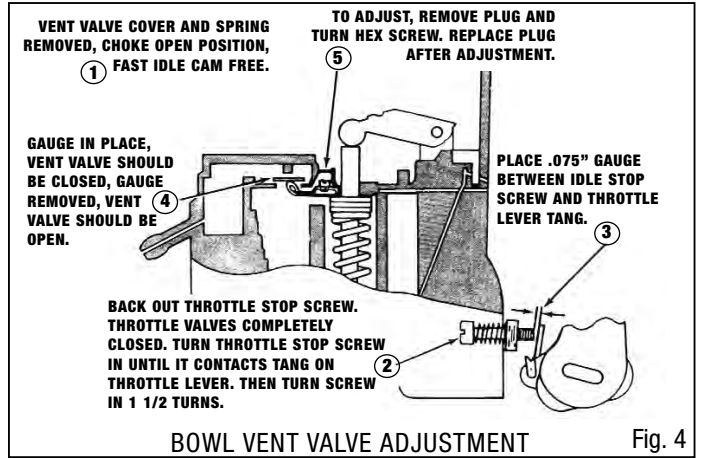
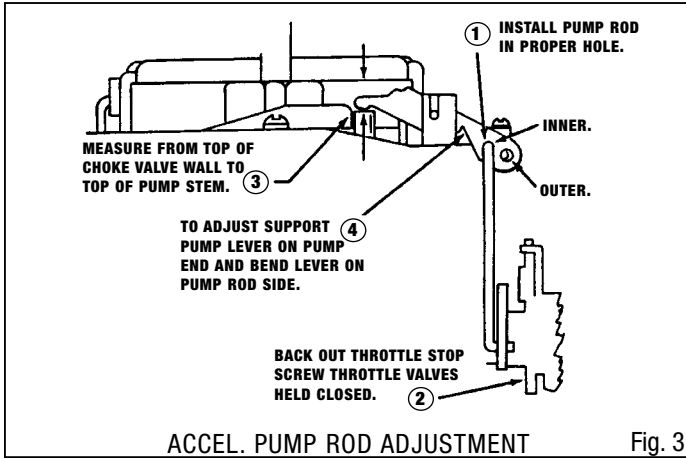
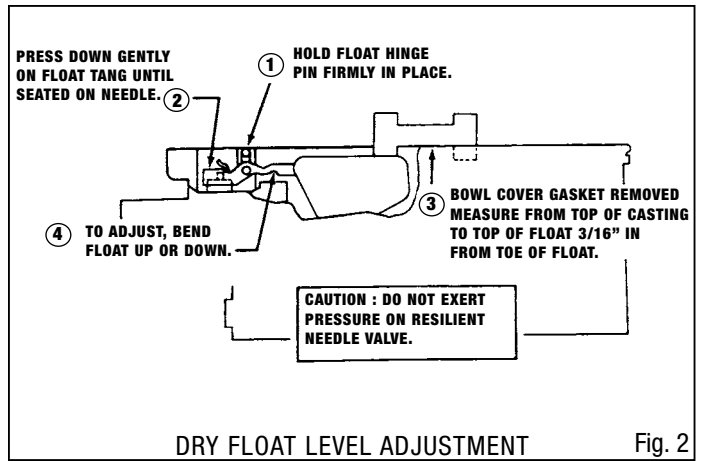
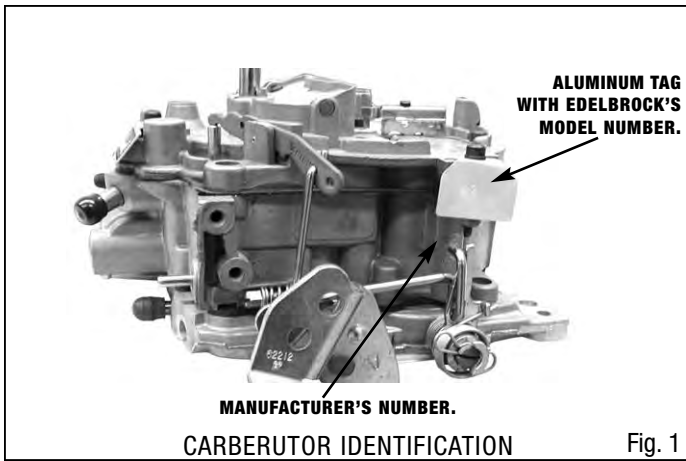

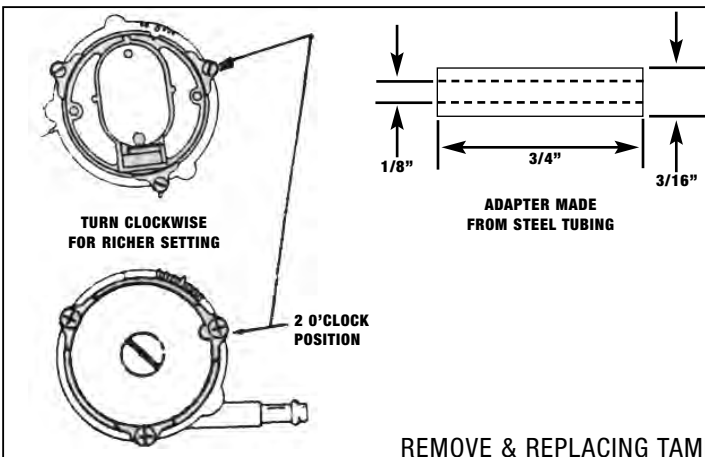
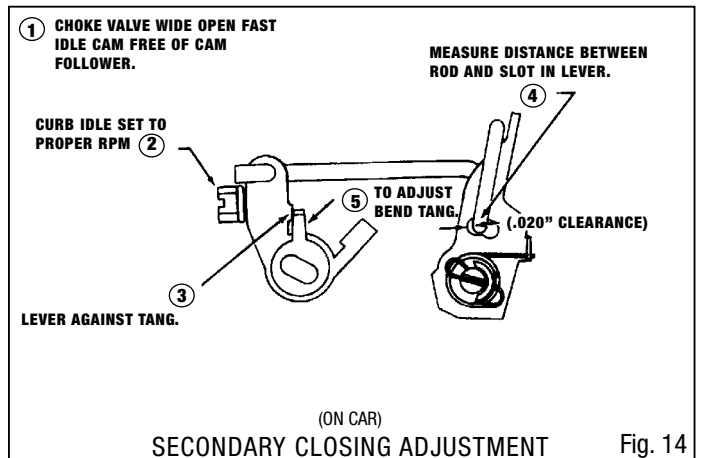
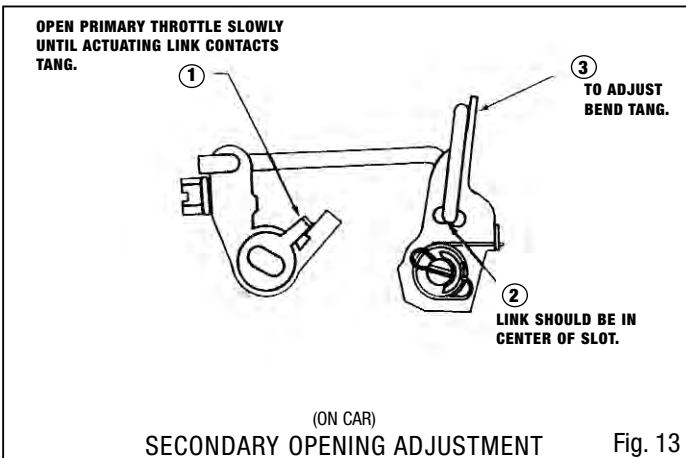
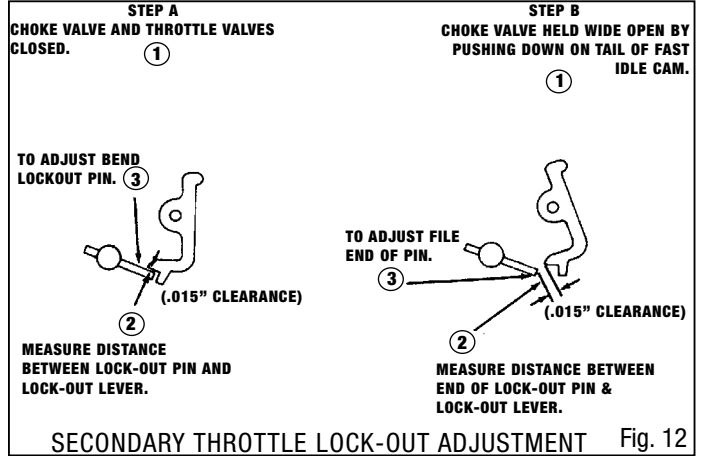
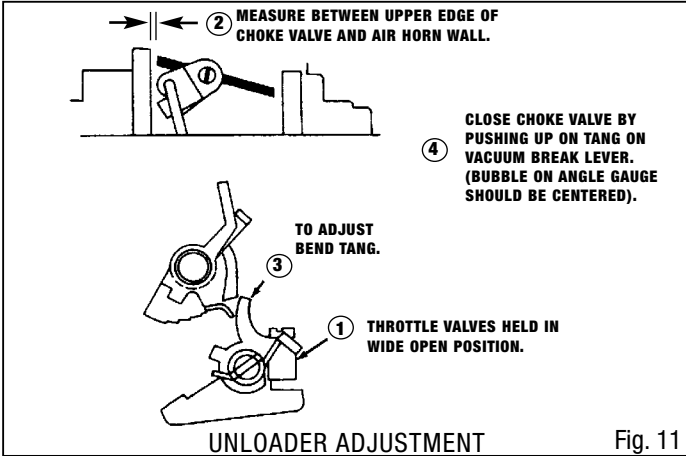
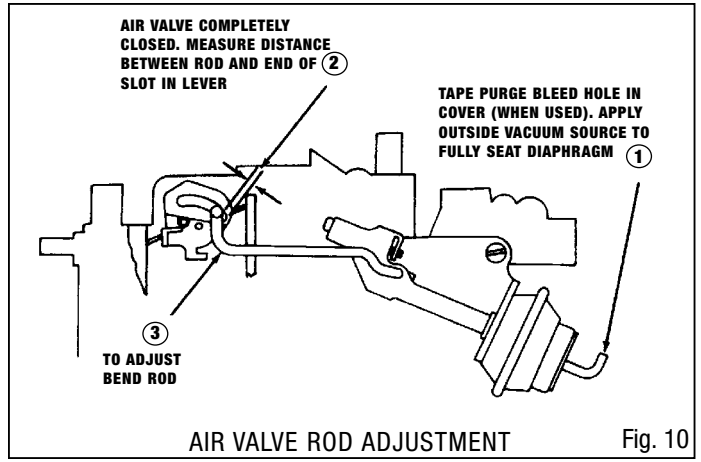
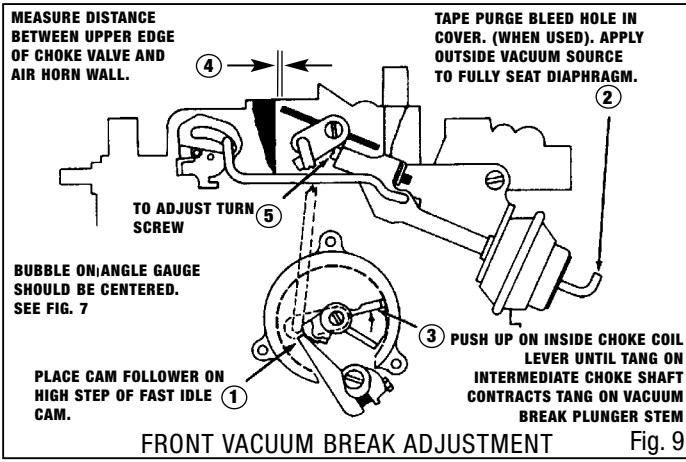

DISASSEMBLY: CAREFULLY ALIGN A #21 DRILL (.159") ON PO RIVET HEADS AND DRILL ONLY ENOUGH TO REMOVE RIVET HEAD, DRILL ALL RIVET HEADS (3) AND USE A DRIFT PUNCH AND HAMMER TO DRIVE THE REMAINDER OR THE RIVETS OUT OF THE CHOKE HOUSING. REMOVE CHOKE COMPONENTS.

REASSEMBLY: PLACE CHOKE CAP IN PLACE AND ROTATE CLOCKWISE UNTIL COIL TANG ENGAGES LEVER TANG AND CLOSES CHOKE VALVE. IT IS IMPORTANT THAT THIS ENGAGEMENT IS ACHIEVED FOR PROPER OPERATION.

MODEL 1903: ROTATE AND ALIGN THE NOTCH IN THE COVER WITH THE PROTRUSION ON THE RETAINER INSTALLED AT THE 2 O'CLOCK POSITION.

MODEL 1904: ROTATE AND ALIGN THE NOTCH IN THE COVER WITH THE RAISED CASTING BOSS AT THE 2 O'CLOCK POSITION. RETINING THE COVER WITH THE POP RIVETS PROVIDED IN THE KIT. IT MAY BE NECESSARY TO USE AN ADAPTER (TUBE) IF INSTALLATION TOOL INTERFERES WITH THE ELECTRICAL CONNECTION TOWER IN THE CHOKE COVER.

EXPLODED VIEW OF TYPICAL EDELBROCK CARBURETOR

PART DESCRIPTION

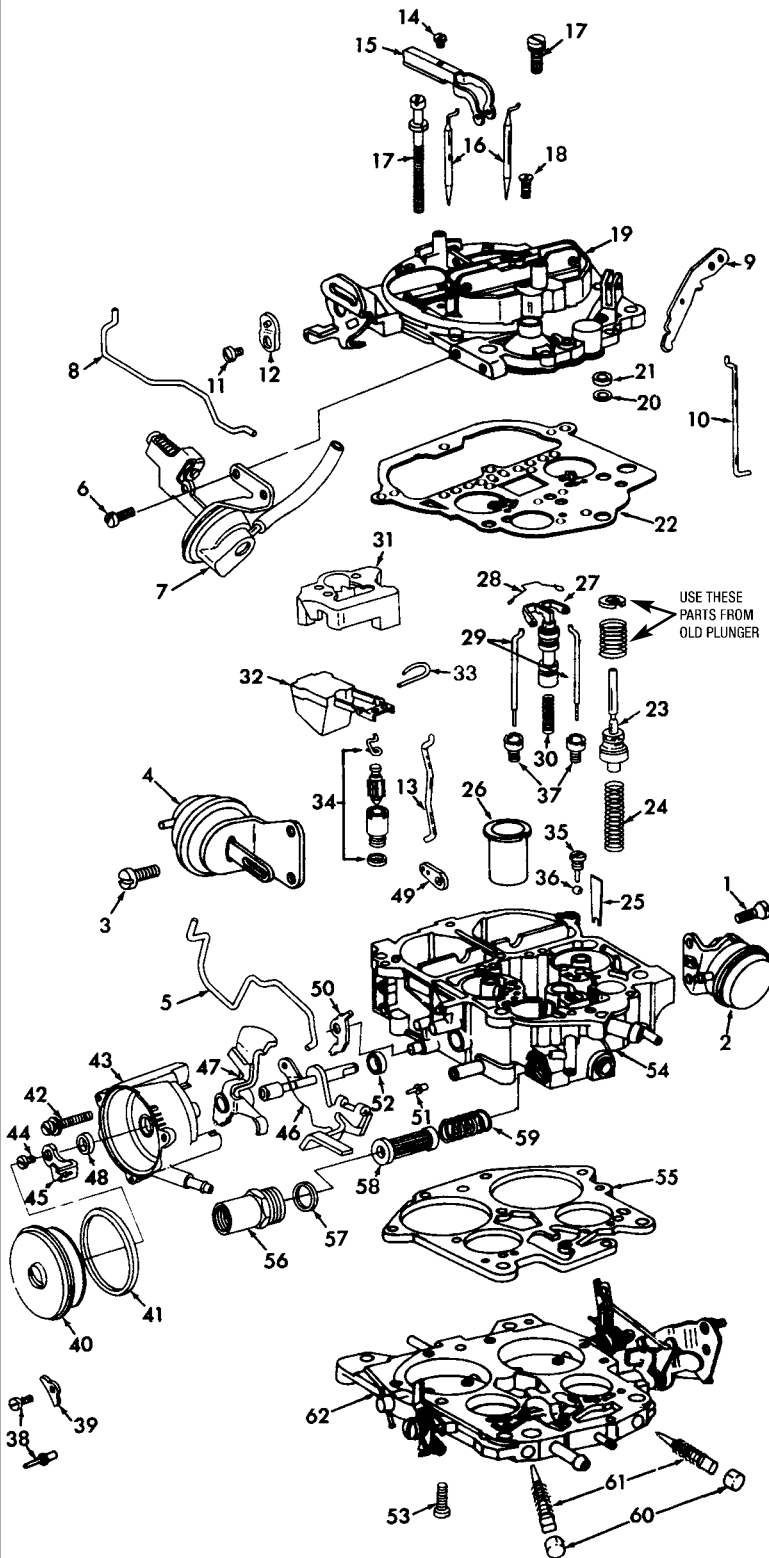

1. SCREW (2) - THROTTLE LEVER ACTUATOR
2. THROTTLE LEVER ACTUATOR ASSY.
3. SCREW (2) REAR VAC. BREAK
4. REAR VAC BREAK ASSY.
5. LINK -REAR VAC. BREAK
6. SCREW (2) - FRONT VAC. BREAK
7. FRONT VAC. BREAK & HOSE ASSY .
8. LINK - FRONT VAC. BREAK
9. LEVER - PUMP
10. ROD - PUMP
11. SCREW - CHOKE LEVER
12. LEVER - CHOKE SHAFT
13. ROD - CHOKE
14. SCREW - SEC. METERING ROD HOLDER
15. HOLDER -SEC. METERING RODS
16. METERING ROD (2) - SECONDARY
17. SCREW & LOCKWASHER - BOWL COVER
18. SCREW (2) -BOWL COVER (TAPERED HEAD)
19. BOWL COVER ASSY.
20. RETAINER - PUMP STEM SEAL
21. SEAL - PUMP STEM (1980 UP')
22. GASKET - BOWL COVER
23. PUMP PLUNGER ASSY.
24. SPRING - PUMP RETURN
25. BAFFLE PUMP WELL
26. INSERT - ANERIOD CAVITY (SOME MODELS)
27. POWER PISTON ASSY.
28. SPRING - METTERING ROD
29. METERING ROD (2) - PRIMARY
30. SPRING - POWER PISTON
31. INSEAT - FLOAT BOWL
32. FLOAT & LEVER ASSY.
33. HINGE PIN - FLOAT
34. NEEDLE, SEAT & GASKET ASSY.
35. PLUG - PUMP DISC. BALL
36. BALL - PUMP DISC.
37. JET (2) - MAIN METERING
38. SCREW / RIVET (3) - RETAINER
39. RETAINER (3) -CHOKE COVER
40. CHOKE COVER ASSY.
41. GASKET -CHOKE COVER (HOT AIR ONLY)
42. SCREW & LOCKWASHER - CHOKE HOUSING
43. CHOKE HOUSING ASSY.
44. SCREW - STAT COIL LEVER
45. LEVER - STAT COIL
46. SHAFT ASSY. - INTERMEDIATE CHOKE
47. CAM. - FAST IDLE
48. SEAL - CHOKE HOUSING
49. LEVER - INTERMEDIATE CHOKE
50. CAM - SECONDARY LOCKOUT
51. TUBE - VAC. PASSAGE
52. SEAL - INTERMEDIATE CHOKE SHAFT
53. SCREW & LOCKWASHER (3) - THROTTLE BOOY
54. FLOAT BOWL ASSY.
55. GASKET -THROTTLE BODY
56. FILTER NUT - FUEL INLET
- 57 . GASKET - FILTER NUT
58. FILTER - FUEL
59. SPRING - FILTER
60. PLUG (2) - IDLE NEEDLE (NOT REPLACED)
61. NEEDLE & SPRING ASSY. (2) - IDLE ADJ.
62. THROTTLE BODY ASSY.