



**Carbureted Victor Jr. & Super Victor LS1 Intake Manifold
for GM 5.7L LS1 or Gen IV L76/L92/LS3 V8 Engines
Part #2908, #29087, #28097 & #28457
INSTALLATION INSTRUCTIONS**

PLEASE study these instructions carefully before installing your new Intake Manifold. If you have any questions, do not hesitate to contact our **Technical Hotline at: 1-800-416-8628**, from 7am-5pm, Pacific Standard Time, Monday through Friday.

- **MANIFOLD:** The Victor Jr. and Super Victor LS1 Intake Manifolds allow the user to retro-fit any GEN III/IV-based longblock into an early or custom vehicle, using a carburetor. These manifolds are intended for use in racing classes where EFI is not desired or allowed. Manifold kit #2908 includes an electronic Timing Control Module, which picks up MAP, Crank Position, and Cam Position sensor outputs, and drives the stock Coil-On-Plug ignition system. Included are several timing curve “pills” that are each tailored for different camshafts, final drive gearing, and vehicle weight (*See Timing Curve Application Chart in the Timing Control Module Installation section for details*). Part # 29087 is the same intake manifold as #2908, but does not include the Timing Control Module. Super Victor manifold #28097 is intended for high performance race engines using large profile camshafts and forced induction or significantly increased compression ratios. Victor Jr. manifold #28457 is intended for use on Gen III or IV blocks equipped with L76/L92/LS3 cylinder heads. A timing module will be required for proper operation of the ignition system with this manifold. Edelbrock timing module #91238 is recommended for Gen III engines equipped with a 24x reluctor wheel, while MSD ignition controller #6012 is recommended for Gen IV engines equipped with a 58x reluctor wheel.
- **EGR SYSTEM:** These manifolds will not accept EGR (exhaust gas recirculation) equipment. EGR systems are used on most 1972 and later model vehicles, up to certain GVWs. Check local laws for requirements. These manifolds are not legal for use in California on pollution-controlled motor vehicles.
- **ACCESSORIES & INSTALLATION ITEMS:** Major recommendations are listed below. However, because these manifold systems are intended for engine swaps into a variety of vehicles, some customization may be required.
- **POWER PACKAGE:** We offer two hydraulic roller camshafts, part #2215 & #2216, and full length race headers for LS1 engines. See our catalog or website for details.
- **CAUTION:** Make sure the vehicle’s battery has been disconnected and that the vehicle is supported on a level surface to prevent any possibility of the vehicle moving during the installation procedure.
- **CARBURETOR RECOMMENDATIONS:** If parts required for installation are unavailable locally, contact Edelbrock directly. Please note that the Edelbrock carburetors recommended below are designed for use with non-EGR applications and do not have any provision for an evaporative canister. Thunder series carburetors include an additional secondary air door and are recommended to achieve the best possible performance.

CARBURETOR	NOTES
Thunder Series P/N 1805 (650 cfm, manual choke) Thunder Series P/N 1806 (650 cfm, electric choke)	Ideal for street driven and/or smaller displacement applications (4.8L & 5.3L)
Performer Series P/N 1407 (750 cfm, manual choke) Performer Series P/N 1411 (750 cfm, electric choke)	Works well with a larger displacement (6.0L) street driven application.
Performer Series P/N 1412 (800 cfm, manual choke) Performer Series P/N 1413 (800 cfm, electric choke)	Recommended for displacements greater than 6.0L and/or vehicles that will see frequent track or strip time.
Thunder Series P/N 1813 (800 cfm, electric choke) Thunder Series P/N 1813 (800 cfm, electric choke)	Recommended for displacements greater than 6.0L and/or vehicles that will see frequent track or strip time.

- **CAMSHAFT AND HEADERS:** The Victor Jr. and Super Victor intake manifolds are compatible with a variety of aftermarket camshafts and/or headers. Edelbrock has developed two Performer RPM camshafts, part #2215 and #2216, which are suitable for use with the LS1 Victor Jr. intake manifold. When using headers, header primary tube diameter should be 1-3/4”. Super Victor manifold owners should consult their engine builder for recommendations.

- **INSTALLATION PROCEDURE:**

1. (**Note:** Use only original equipment (GM P/N 12533587 for LS1; GM P/N 12590125 for L92/LS3) O-Ring type gaskets when installing Victor Jr. intake manifolds, use Fel-Pro standard gaskets #1312-3 with Super Victor manifold #28095). No gasket sealer is required when using the OEM type gaskets. Use the supplied 6mm hex head bolts and 1/4" AN washers to mount the manifold to the cylinder heads.
2. (Does not apply to #28457) The Gen III throttle bracket mounts under the two left side rear intake manifold bolts, and the timing control module bracket is mounted under the two right rear bolts.
3. Following the torque sequence in **Figure 1**, torque all manifold bolts to 11 ft/lbs.
4. (Does not apply to #28097 or #28457) Select the appropriate cable brackets for your application (large or small opening brackets) and attach them to the GEN III throttle bracket base with the appropriate number of 6mm x 1.0 x 12mm serrated flange hex bolts. (**Note:** In our retrofit of the LS1 into a 1974 Camaro, using a TH400R automatic transmission, we only needed one of the small opening cable brackets for the throttle cable, since a kickdown cable is not used. See **Figure 2** for example.)
5. (#2908 Only) Apply a bit of liquid Teflon thread sealant to the threads of the supplied 1/8" NPT to 1/4" hose fitting and install the fitting into the 1/8" NPT hole in the passenger side of the plenum (See **Figure 1**). Install your carburetor and using the rear passenger side carburetor stud/nut, attach the MAP sensor and bracket to the carburetor (See **Figure 3**). Connect the sensor to the fitting with the supplied 1/4" hose.

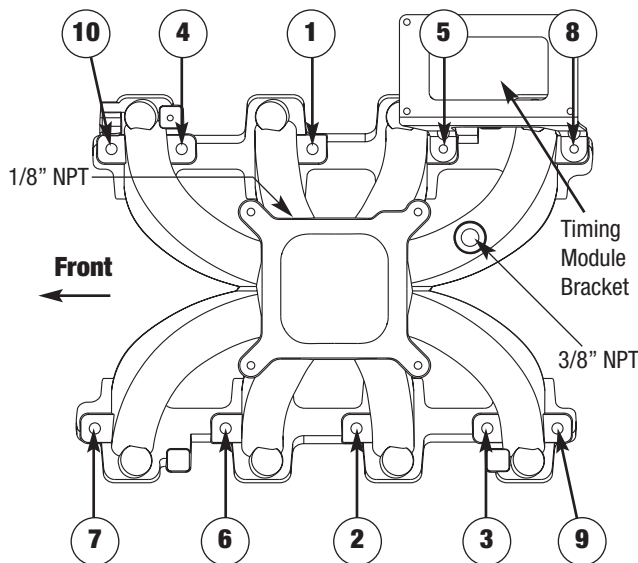

Figure 1 - Intake Manifold Tightening Sequence

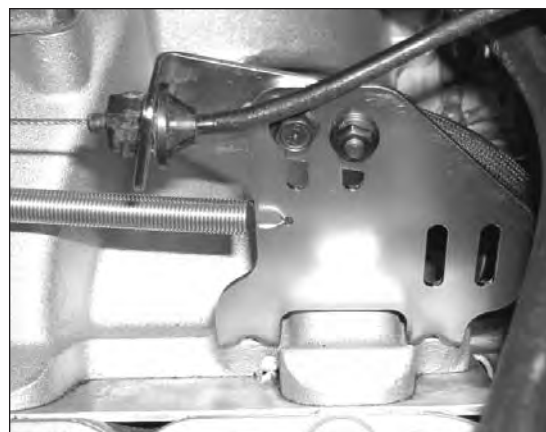

Figure 2 - Throttle Cable Bracket

- **TIMING CONTROL MODULE INSTALLATION (#2908 ONLY):**

1. Using the supplied rubber isolators included with the Timing Control Module, plus the four locknuts, attach the module to the bracket. Mount the module so that the main harness will face forward.
2. Locate the Crankshaft Position Sensor connector. It is the three-wire connector (pink, brown, and orange with yellow stripe) at the end of the long section of harness which is encased in a smooth, rubberized, dark grey heatshield. Route this line down the passenger side rear of the engine, and connect it to the Crankshaft Position Sensor. The Crankshaft Position Sensor is located on the rear of the passenger side of the engine, just above the oil pan rail (See **Figure 4**).
3. Locate the MAP Sensor connector. It is the three-wire connector with orange, green, and brown wires. Connect this to the MAP Sensor which is now attached to the passenger side rear carburetor mounting stud.
4. Locate the Camshaft Position Sensor connector. It is a three-wire connector with a pink wire, brown, and a brown wire with a white stripe. Connect this to the Camshaft Position Sensor, located at the rear/top of the block. This is where the distributor would be mounted on an early small block Chevrolet engine (See **Figure 5**).
5. Connect the 7-wire connectors to each coil pack. The connector that is part of the main wiring harness (leading to the passenger side) with the following wire colors: brown, white with blue stripe, purple with blue stripe, pink, black, red with green stripe, and brown with green stripe, is connected to cylinder numbers 2, 4, 6, & 8 (Passenger side cylinder bank). The connector that is wired separately from the main harness, with the following wire colors: black, red, green, brown, light blue, purple, and pink, connected to cylinder numbers 1, 3, 5, & 7 (Driver side bank).



Figure 3 - Map Sensor and Bracket

6. Locate the portion of the harness with the four non-terminated wires (Pink, Blue, Black, & Yellow). These will be connected to the following sources:

Pink	Main power. Connect to a SWITCHED ignition power source. 12v should be measured only with ignition key in the "START" and "ON" positions.
Black	Chassis ground.
Blue	A/C compressor. If A/C is being used in your application, use Edelbrock Idle Compensator #8059 and connect blue wire to A/C compressor. Connect the other blue wire at the 1, 3, 5, 7 cylinder coil pack connector to the lead on #8059. This provides increased idle speed while the A/C compressor is running. (Tip: In applications with a radical cam, that have trouble with "run-on" after shut down, use Edelbrock Idle Compensator #8059 to open the throttle by connecting #8059 and blue wire to a switched 12 volt source. This allows increased throttle to support a high duration cam, yet allows throttle to be fully closed when key is in the "OFF" position.) If wires are not being used, secure out of the way and cover end with electrical tape to prevent accidental connection.
Yellow	Standard V8 tachometer output signal. If not in use, secure out of the way and cover end with electrical tape to prevent accidental connection.

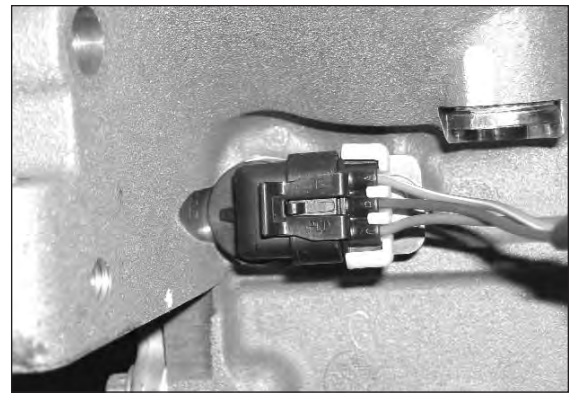

Figure 4 - Crankshaft Position Sensor



Figure 5 - Camshaft Position Sensor

• **FINAL TUNING FOR OPTIMUM PERFORMANCE (#2908 ONLY):**

1. Generally speaking, the stock jetting for the carburetors listed previously in the "Carburetor Recommendations" section will not need changing. Some applications may show a performance increase by recalibrating the fuel metering circuits using jets, rods, and other parts available from Edelbrock.
2. Included with the Timing Control Module are six timing curve "pills". Using the chart below, select the curve that best suits your application.

CURVE #	CAMSHAFT	VEHICLE
1	Stock or Mild	Heavy or Low Ratio Gear
2	Stock or Mild	Medium or Standard Ratio
3	Stock or Mild (Default)	Light or High Ratio Gear
4	Z06 or Edelbrock #2215 (some overlap)	Medium or High Ratio Gear
5	Z06 or Edelbrock #2215 (some overlap)	Light w/ Standard Ratio or High Ratio Gear
6	HIGH OVERLAP; Edelbrock #2216	Light w/ High Ratio Gear

Note: Low Ratio = Approximately 3.20-3.50:1, Standard = Approx. 3.40-3.73:1, & High = Approx. 3.90-4.11:1 (or higher)

KIT CONTENTS:

Qty.	Description	Included in Manifolds:
1	Intake Manifold	All
10	6mm x 50mm Hex Head Capscrew	All (28457 includes 4x 90mm and 6x 50mm long capscrews)
10	¼" AN Washer	All
1	GEN III Throttle Bracket Base	2908 & 29087
2	Cable Bracket (Small Opening)	2908 & 29087
2	Cable Bracket (Large Opening)	2908 & 29087
4	6mm x 1.0 Serrated Flange Hex Nut	2908 & 29087
4	6mm x 1.0 x 12mm Serrated Flange Hex Bolt	2908 & 29087
.75'	¼" I.D. Vacuum Hose (For MAP)	2908
1	Timing Control Module & Hardware	2908
4	Nylock Nuts	2908
1	MAP Sensor Bracket	2908
1	LS1 type MAP Sensor (1 Bar)	2908
1	Timing Control Module Bracket	2908
1	1/8"NPT to ¼" Hose Fitting (For MAP)	2908 & 28457
1	3/8" NPT Pipe Plug	28457



Edelbrock Corporation • 2700 California St. • Torrance, CA 90503
Tech Line: (800) 416-8628